

6.2.1 TECHNICAL DATA

MAX OPERATING PRESSURE (PS): 360 bar

PRESSURE TEST (PT): 1.43 x PS

NOMINAL CAPACITIES: 3 - 5 - 10 - 15 - 20 - 25 - 35 - 55 litres

WORKING TEMPERATURE: -40 ÷ +150 °C

BODY MATERIAL- carbon steel shell painted with rust inhibitor RAL 8012
 - nickel coating 25 - 40 µ
 - internal and external coating with RILSAN th. 0.6 mm

VALVES MATERIAL: - phosphated or
 - galvanized carbon steel in compliance with Directive 2002/95/EC (RoHS) to resist to corrosion
 - stainless steel AISI 316L
 - nickel coating 25-40 µ

SEALS MATERIAL: - **P** = Nitrile rubber (NBR)
 - **F** = Low temp. nitrile rubber
 - **H** = Nitrile for hydrocarbons
 - **K** = Hydrogenated nitrile (HNBR)
 - **B** = Butyl (IIR)
 - **E** = Ethylene-propylene (EPDM)
 - **N** = Chloroprene (Neoprene)
 - **Y** = Epichlorohydrin (ECO)
 - **V** = Fluorocarbon (FKM)

See Table 6.2c and/or Chapter 1.5

CONNECTIONS: see Table 6.2db - 6.2dc - 6.2df

WEIGHT: see Table 6.2db- 6.2df

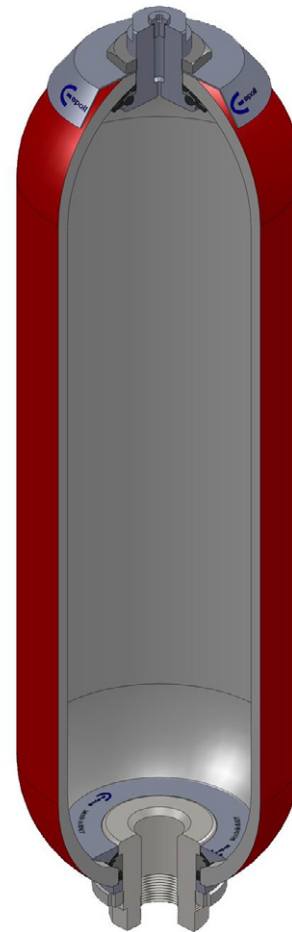

6.2a

6.2.2 DESCRIPTION

Additional bottles type ASS consist of a seamless cylindrical pressure vessel made of high-tensile steel.

They are derived from the same shells of the AS bladder accumulator. The additional bottles are used to take in and store nitrogen to increase the gas volume in the accumulator station (with bladder or piston accumulator). This means that smaller accumulators can be used for the same gas volume and costs can be reduced. EPE offers a wide selection of bottles type, such as forged "B" version, shell of bladder accumulator "ASS" and "ASSA" versions or body piston type "AB" version.

6.2.4 HYDRAULIC SYMBOL

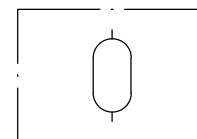

6.2b

6.2.3 "ASS" ADDITIONAL CYLINDERS ADVANTAGES

- compact
- simple construction
- wide range of small-medium capacity
- works well on water, low lubricity fluids
- quick, easy installation

6.2.5 SEALS-TEMPERATURE-LIQUID COMPATIBILITY

When selecting the additional cylinder variant, pay attention to the following non-binding notes with regard to hydraulic fluid, seals material and the permissive temperature range. (see Section)

Code letter	Polymer	ISO	Temperature range (°C)	Some of the liquids compatible with the polymer
P	Standard nitrile (Perburan)	NBR	-20 ÷ +80	Aliphatic hydrocarbons (propane, butane, gasoline, oils, mineral greases, diesel fuel, fuel oil, kerosene), mineral greases and oils, HFA - HFB - HFC fluids, many dilute acids, alkalis, saline solutions, water, water glycol.
F	Low temperature nitrile	NBR	-40 ÷ +70	The same as with standard nitrile + a number of different types of Freon. (This contains less acrylonitrile than the standard and is therefore more suitable for low temperatures, but its chemical resistance is slightly lower).
H	Nitrile for hydrocarbons	NBR	-10 ÷ +90	Regular and premium grade slightly aromatic gasoline (and all the liquids for standard nitrile).
K	Hydrogenated nitrile	HNBR	-30 ÷ +130	The same as with standard nitrile but with excellent performance at high and low temperatures.
B	Butyl	IIR	-30 ÷ +100	Hot water up to 100°C, glycol-based brake fluids, many acids and bases, salt solutions, polar solvents such as alcohols, ketones and esters, polyglycol-based hydraulic fluids (HFC fluids) and bases of esters of phosphoric acid (HFD-R fluids), silicone oils and greases, resistance to ozone, aging and weathering.
E	Ethylene-Propylene	EPDM	-30 ÷ +100	Hot water up to 100°C, glycol-based brake fluids, many organic and inorganic acids, detergents, solutions of sodium and potassium, phosphate ester-based hydraulic fluids, (HFD-R), silicone oils and greases, many polar solvents (alcohol, ketones, esters), Skydrol LD4 and 500B-4, resistance to ozone, aging and weathering.
N	Chloroprene (Neoprene)	CR	-30 ÷ +100	Mineral oils of paraffin, silicone oils and greases, water and aqueous solutions, refrigerants (ammonia, carbon dioxide, Freon), naphthenic mineral oils, low molecular aliphatic hydrocarbons (propane, butane, fuel), brake fluids based on glycol, better resistance to ozone, weathering and aging compared to NBR rubber.
Y	Epichloridrin	ECO	-30 ÷ +110	Mineral oils and greases, aliphatic hydrocarbons (propane, butane and gasoline), silicone oils and greases, water at room temperature, resistance to ozone, aging and weathering.
V	Fluorocarbon	FKM	-10 ÷ +150	Mineral oils and greases, non-flammable fluids of HFD group, silicone oils and greases, animal and vegetable oils and greases, aliphatic hydrocarbons (gasoline, butane, propane, natural gas), aromatics hydrocarbons (benzene, toluene), chlorinated hydrocarbons (Tetrachloroethylene, carbon tetrachloride), fuel (regular, super and containing methanol), excellent resistance to ozone, weathering and aging.

For other hydraulic fluid and/or temperatures, please consult us.

6.2c

6.2.6 ORDER CODE

1	2	3	4	5	6	7	8	9
ASS	25	P	360	C	G	5	VT	- 8

1	Series
	Additional bottle = ASS

2	Nominal capacity (litres)
	3 = 3
	5 = 5
	10 = 10
	15 = 15
	20 = 20
	25 = 25
	35 = 35
	55 = 55

3	Seals material material
	Nitrile rubber (NBR) = P
	Nitrile for low temp. = F
	Nitril for hydrocarbons = H
	Hydrogenated nitrile (HNBR) = K
	Butyl (IIR) = B
	Ethylene-propylene (EPDM) = E
	Chloroprene (Neoprene) = N
	Epichlorohydrin (ECO) = Y
	Fluorocarbon (FKM) = V

4	Max working pressure (PS)
Capacity litres	Carbon steel
3 ÷ 55	360
	210 only for the version with connection L

5	Body material
	Carbon steel = C
	Nickel coated carbon steel 25 μ = N
	Nickel coated carbon steel 40 μ = M
	Rilsan coating = V

6	Bottom connection
	BSP ISO 228 (std) = G
	adapter for flange SAE 3000 Psi = L
	adapter for flange SAE 6000 Psi = H

9	Test and certification
	Factory testing = 0
	Australian Standard = 2
	ML (China) = 3
	RINA = 4
	Lloyd's Register = 5
	PED 2014/68/EU (for capacities greater than 1 l) = 8
	ATEX 2014/34/EU (for surface) = 9
	ATEX 2014/34/EU (for mine) = 9M
	DNV = 10
	EAC (Russia) = 11
	Algeria passport = 12
	Standard regulation (NR13) (Brazil) = 13
	Tunisian passport = 14
	Bureau Veritas = 15
	ABS = 16
	CCS = 17
	Dosh = 20
	CRN = 21

8	Top connection
	Thread hole M12x1.5 plugged = VT
	1/4" BSP ISO 228 = G2
	1/2" BSP ISO 228 = G4
	3/4" BSP ISO 228 = G5
	1" BSP ISO 228 = G6
	1"1/4 BSP ISO 228 = G7
	1"1/2 BSP ISO 228 = G8

7	Bottom connection dimension
	For the type of connection:
	G 3/4" BSP ISO 228 = 5
	1" BSP ISO 228 = 6
	1"1/4 BSP ISO 228 = 7
	1"1/2 BSP ISO 228 = 8
	L (3÷5 l) 1" 1/4 SAE3000 = 7
	(10÷55 l) 1" 1/2 SAE 3000 = 8
	2" SAE 3000 = 9
	H (3÷5 l) 1" 1/4 SAE6000 = 7
	(10÷55 l) 1" 1/2 SAE 6000 = 8
	2" SAE 6000 = 9
	Special variants upon request

6.2.7 DIMENSIONS

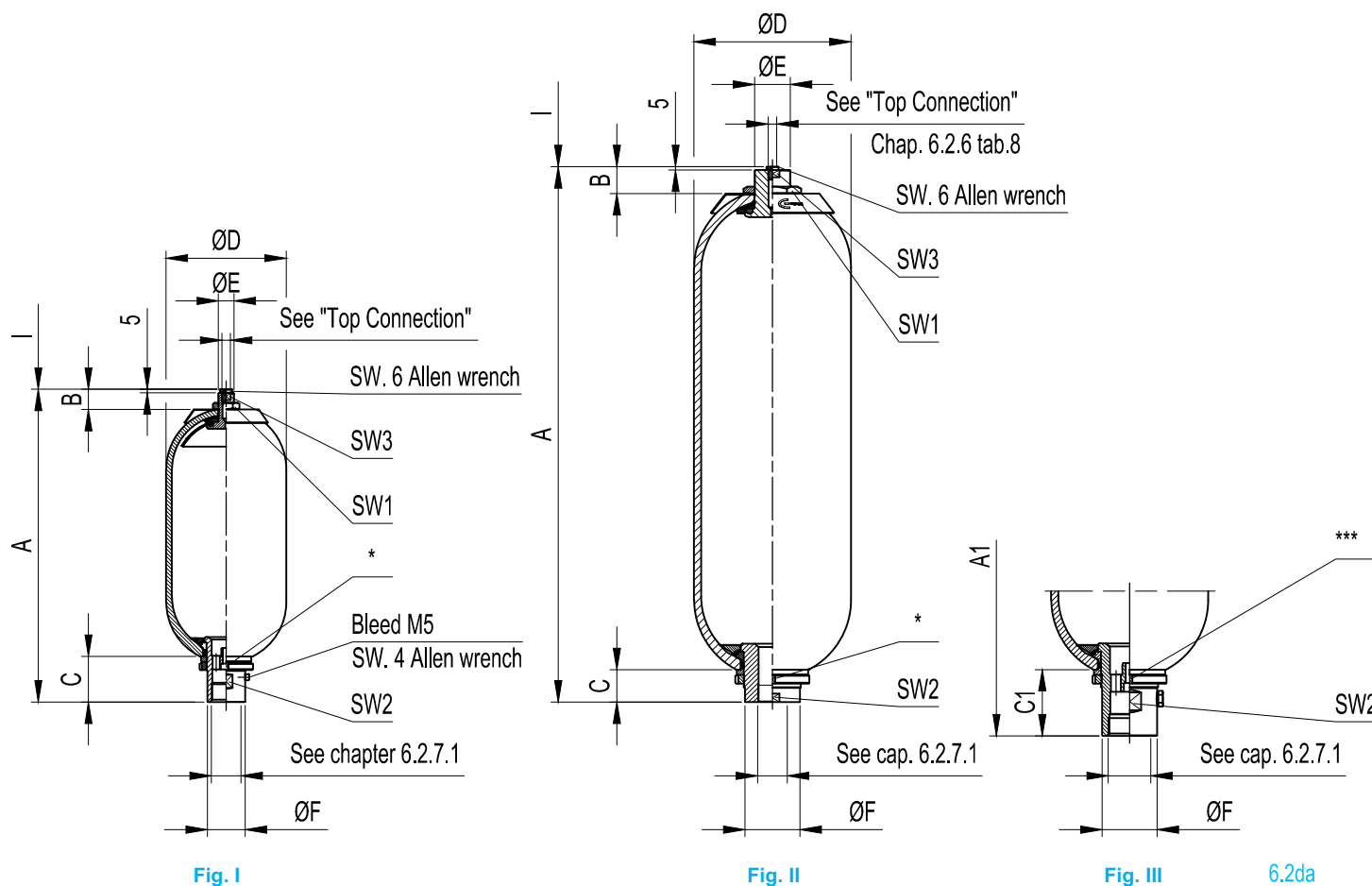

Acc. type ASS in carbon steel	Nominal gas volume litres	Working pressure bar	Ped cat. fluids of group 2 AS	Fig.	A mm	A1** mm	B mm	C mm	C1** mm	ØD mm	ØE mm	ØF mm	I mm	SW 1 mm	SW 2 mm	SW 3 mm	Acc. dry weight kg
ASS 3	3	360	III	I	534 ± 8	-	28	65	-	114	M22x1,5	53	140	32	50	18	8
ASS 5	5	360	III	I	438 ± 10	-	28	65	-	168	M22x1,5	53	140	32	50	18	13
ASS 10	10	360	IV	II-III	500 ± 10	546 ± 10	35	55	93	220	M50x1,5	77	140	70	70	41	31
ASS 15	15	360	IV	II-III	650 ± 10	696 ± 10	35	55	93	220	M50x1,5	77	140	70	70	41	41
ASS 20	20	360	IV	II-III	810 ± 10	856 ± 10	35	55	93	220	M50x1,5	77	140	70	70	41	45
ASS 25	25	360	IV	II-III	975 ± 15	1021 ± 15	35	55	93	220	M50x1,5	77	140	70	70	41	56
ASS 35	35	360	IV	II-III	1325 ± 15	1371 ± 15	35	55	93	220	M50x1,5	77	140	70	70	41	74
ASS 55	55	360	IV	II-III	1835 ± 15	1881 ± 15	35	55	93	220	M50x1,5	77	140	70	70	41	102

* For tools see chapter 6.2.12 table 6.2di

** Only for connection type "A" see chapter 6.2.7.1

6.2db

- The maximum differential pressure is the maximum allowable difference between the maximum pressure and the minimum working pressure (P2-P1) to have an infinite life cycle of the accumulator (greater than 2,000,000 cycles).

- Flow rate measured using mineral oil with viscosity of 36 cSt at 50°C and $\Delta P = 5$ bar

6.2.7.1 STANDARD THREAD CONNECTIONS

Dimensions	Connection Type	Accumulator type	Complete spare valve order code	Ød	ØD mm	ØF mm	H mm
	A BSP ISO 228 with chamfer for OR	ASS 3	V 2250-A7-***	1" 1/4 BSP	46	53	25
		ASS 5	V 2253-A7-***				
		ASS 10 ÷ 55	V 2064-A9-***	2" BSP	63,35	77	28
	G BSP ISO 228	ASS 10 ÷ 55	V 2267-G8-***	1" 1/2 BSP	-	77	25

* Gasket material

** Components material

6.2dc

6.2.7.2 ADAPTER FOR FLANGE SAE 3000/6000 PSI (L/H)

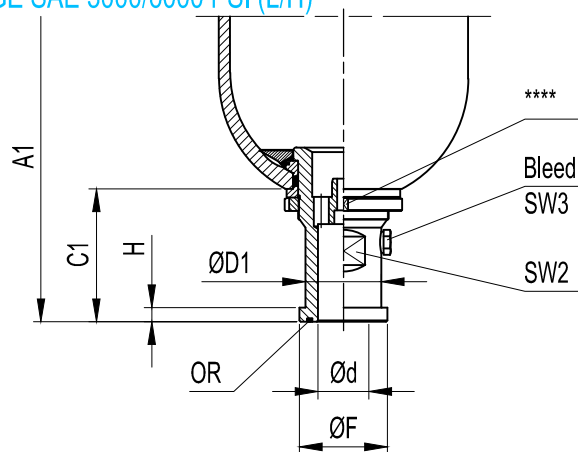

6.2de

Acc. type ASS in carbon steel	Dim.	A1 mm	C1 mm	SW2 mm	SW3 mm	Bleed	Ød mm	SAE 3000 (L)			SAE6000 (H)			OR	Acc. dry weight kg		
								Spare valve order code	ØD1 mm	ØF mm	H mm	Spare valve order code	ØD1 mm			ØF mm	H mm
ASS 3	1"	589 ± 8	100	38	4***	M5	-	-	-	-	V 2025-H6-***	38	47,6	9,5	0010R4131-*	11	
	1"1/4	578 ± 8	89				31	V 2025-L7-***	43	50,8	8	V 2025-H7-***	44	53,3	10,3		0010R4150-*
ASS 5	1"	493 ± 10	100	38	4***	M5	-	-	-	-	V 2044-H6-***	38	47,6	9,5	0010R4131-*	15	
	1"1/4	482 ± 10	89				31	V 2044-L7-***	43	50,8	8	V 2044-H7-***	44	53,3	10,3		0010R4150-*
ASS 10	1"1/2	583 ± 10	115	42	19****	1/4" BSP	32	V 2064-L8-***	50	60,3	8	V 2064-H8-***	51	63,5	12,5	0010R4187-*	33
	2"						45	V 2064-L9-***	62	71,5	9,5	V 2064-H9-***	67	77,6		0010R4225-*	
ASS 15	1"1/2	733 ± 10	115	42	19****	1/4" BSP	32	V 2064-L8-***	50	60,3	8	V 2064-H8-***	51	63,5	12,5	0010R4187-*	43
	2"						45	V 2064-L9-***	62	71,5	9,5	V 2064-H9-***	67	77,6		0010R4225-*	
ASS 20	1"1/2	893 ± 10	115	42	19****	1/4" BSP	32	V 2064-L8-***	50	60,3	8	V 2064-H8-***	51	63,5	12,5	0010R4187-*	48
	2"						45	V 2064-L9-***	62	71,5	9,5	V 2064-H9-***	67	77,6		0010R4225-*	
ASS 25	1"1/2	1058 ± 15	115	42	19****	1/4" BSP	32	V 2064-L8-***	50	60,3	8	V 2064-H8-***	51	63,5	12,5	0010R4187-*	59
	2"						45	V 2064-L9-***	62	71,5	9,5	V 2064-H9-***	67	77,6		0010R4225-*	
ASS 35	1"1/2	1408 ± 15	115	42	19****	1/4" BSP	32	V 2064-L8-***	50	60,3	8	V 2064-H8-***	51	63,5	12,5	0010R4187-*	78
	2"						45	V 2064-L9-***	62	71,5	9,5	V 2064-H9-***	67	77,6		0010R4225-*	
ASS 55	1"1/2	1918 ± 15	115	42	19****	1/4" BSP	32	V 2064-L8-***	50	60,3	8	V 2064-H8-***	51	63,5	12,5	0010R4187-*	108
	2"						45	V 2064-L9-***	62	71,5	9,5	V 2064-H9-***	67	77,6		0010R4225-*	

* Gasket material

** Components material

*** Allen wrench

**** Ex. Wrench

***** see chapter 6.2.11 table 6.2dh

6.2df

6.2.8 SPARE PARTS CODE (STANDARD VERSION)

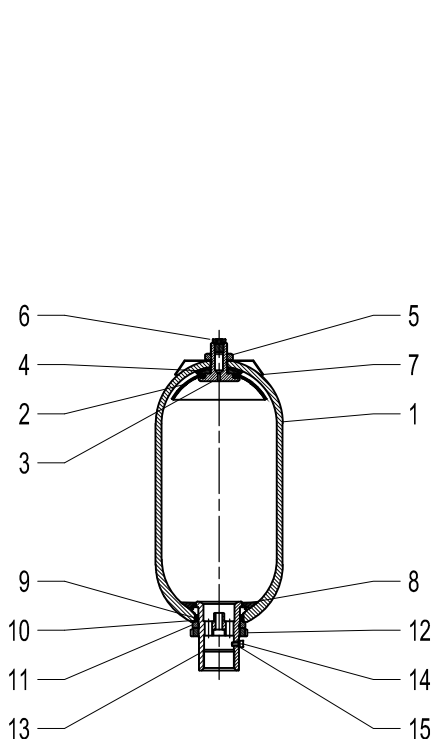

Fig. I

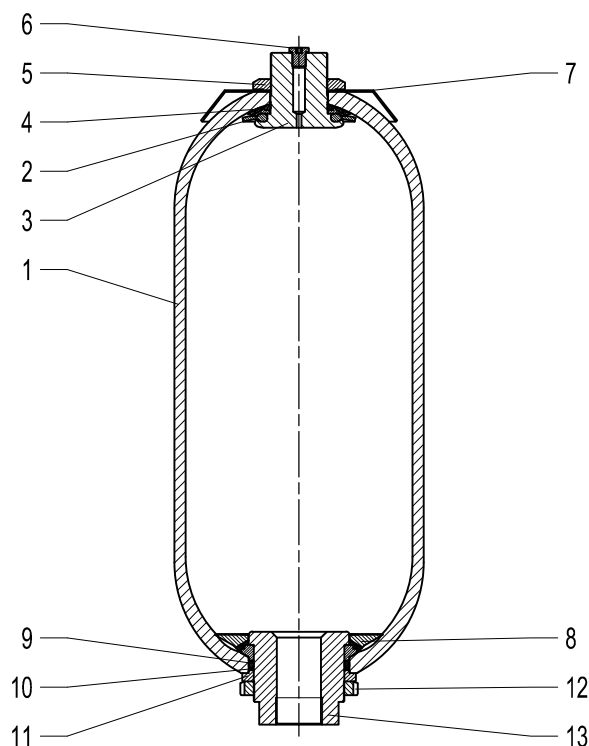

Fig. II

6.2dg

Item	Description	Q.ty	Type		
			ASS 3 (Fig. I)	ASS 5 (Fig. I)	ASS 10 + 55 (Fig. II)
1	Accumulator shell	1	Not supplied as spare part		
2	Seal gas side	1	B11250 - *	B11252 - *	B10052 - *
3	Gas valve body	1	B10107 - **	B10202 - **	B10333 - **
4	Rubber-coated washer	1	B10106 - ** / *	B10205 - ** / *	B10334 - ** / *
5	Gas valve looknut	1	B10109 - **		B10302 - **
6	Plug	1	B10043 - **		
7	Name plate	1	D10300B-A	D10300C-A	D10300D-A
8	Retaining ring	1	B10146 - ** / *	B10222 - ** / *	B10317 - ** / *
9	"O" ring	1	0010R0159 - *	0010R6212 - *	0010R0181 - *
10	Supporting ring	1	B10150-T	B10227-T	B10320-T
11	Space ring	1	B10223 - **		B10319 - **
12	Fluid port ring nut	1	B10217 - **		B10321 - **
13	Fluid port body	1	B10144 - *** - **		B10311 - *** - **
14	Bleed screw ****	1	B10128 - **		-
15	Seal ring ****	1	B10129-R		-
	Standard gas valve ass. (parts 2 ÷ 6)	1	V 2033 - ** / *	V 2049 - ** / *	V 2270 - ** / *
	Standard fluid port ass. (parts 8 ÷ 15)	1	V 2250 - *** - ** / *	V 2253 - *** - ** / *	V 2267 - *** - ** / *
	Gasket sets	1	B2031-1* { B11250-* 0010R0159-* B10150-T	B2050-1* { B11525-* 0010R6212-* B10227-T	B2080-1* { B10052-* 0010R0181-* B10320-T

* Gasket material ** Component material *** See chapter 6.2.6 table 8 - 9
**** Only for Fig. I

6.2dh

6.2.9 EUROPE MARKET

All hydraulic additional bottles are pressure vessels and are subject to the national regulations and directives valid at the place of installation.

For additional cylinders type ASS, every shipping batch is complete of a conformity declaration and instructions of use and. All vessel categories (see Table 6.2d) must be protected by means of a pressure relief valve in accordance with Directive 2014/68/EU.

6.2.10 ACCESSORIES

For support equipment, see section 7

For gas side's safety equipment, see section 8

For pre-loading and charging set, see section 11

For other components, see section 12

6.2.11 COMMISSIONING AND MAINTENANCE

Delivery condition.

Depending on the size and quantity ordered, the additional bottles are shipped in cartons or in cartons on pallets, or wooden boxes upon request. Unless otherwise required, certificates and documentation are provided together with the bottles.

Handling

The original packaging is suitable for handling and storage.

Where necessary, you should use suitable lifting equipment to support the weight of the bottles. However protect from impact the packaging and handle it with care.

Storage

During storage in the warehouse, leave the product in its original packaging, keeping it away from heat sources and naked flames. The storage temperature should be between +10 and +40°C.

After six years of storage, it is essential to proceed with the replacement of all elastomeric parts before the commissioning.

Marking on the nameplate of the additional cylinder.

With reference to the PED 2014/68/EU classification, Article 3, Paragraph 3 and / or risk categories I or IV depending on volume and maximum working pressure, the cylinder indicates the following data:

- logo, name and country of the manufacturer
- month / year of production
- product code
- serial number
- maximum PS pressure and PT test pressure in bar
- min. and max. TS working temperature in Celsius
- volume V in litres
- group of fluids allowed
- CE marking (by category I ÷ IV) with the identification number of the notified body

It is strictly forbidden to:

- weld, rivet, bolt or screw any item of the cylinder shell
- engrave or permanently stamp the surfaces of the cylinder shell and / or carry out other operations that could affect or change the mechanical properties of the cylinder
- use the cylinder as a structural element: it should not be subjected to stresses or loads

- change the data of the nameplate and / or the cylinder without the permission of the manufacturer
- use a (dangerous) fluid of Group 1 with equipment designed and manufactured for fluids of Group 2.

Installation

Before installation, you must perform a visual check to verify that the bottles has not suffered any damage during shipping / handling.

Verify that the requested type matches with what stamped on the nameplate.

We recommend using the additional bottles connected to the accumulator with a suitable safety valve (see Chapter 8).

This device provides user and equipment protection against possible damages due to pressure peaks.

The additional bottles type ASS may be installed in any position from horizontal to vertical (preferably with the connections vertically) and the nameplate must be visible.

Proceed to the assembly so that no abnormal force affects the pipes connected directly or indirectly to the additional bottles, so we recommend the use of supporting components and also fastening (please see Chapter 7) to avoid the transmission of vibrations.

Make sure that the bottle is connected to the hydraulic circuit through suitable connection devices.

Make sure the gas is compatible with the elastomer of the seals.

Check that the max. allowed bottle pressure is equal to or greater than that of the hydraulic circuit and that the temperature during operation is maintained within the range expected.

Make sure the fluid does not contain contaminants.

Maintenance

- Periodically check the pre-charge pressure of the system: after the commissioning, check after 2-3 weeks of operation and if there were no leaks, repeat the operation after 3 months; if the pressure at the same temperature was stable, repeat the test yearly. For heavy-duty applications, check the pre-charge every 6 months.
- Periodically (yearly) carry out a visual inspection of the bottle in order to detect any early signs of deterioration such as corrosion, deformation, etc.
- Comply with the requirements of the regulations concerning the verification of the functionality of the equipment according to the country of installation of the bottle.

Disassembly

If for failure, scheduled check or retest it is necessary to remove the additional bottle from the system, prior to removal, completely discharge the pressure within the circuit.

All additional EPE bottles of the ASS series can be repaired.

Repair

It can consist in replacing the seals and/or parts of the valves.

For reasons of functionality and security, it is recommended to use only original spare parts.

Demolition and recycling of the additional cylinder

Before demolition or recycling of the additional bottle, you should always discharge the internal pressure.

If needed, proceed decontaminating in relation to the gas/fluid used prior to demolition.

6.2.12 SPANNER WRENCH

Fits all standard size additional bottle type ASS, it is used to remove or install lock nut on fluid port assembly.

0.7÷1.5 lt code 2506/58

3÷5 lt code 2506/68

10÷55 lt code 2506/105

Dimension

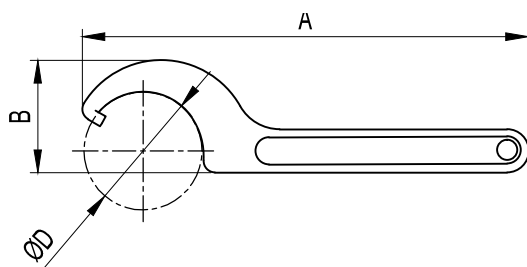

CODE	A	B	ØD	For Accumulator
B2506/58	241	45	58	0.7 ÷ 1.5
B2506/68	241	43	68	3 ÷ 5
B2506/105	336	82	105	10 ÷ 55

6.2di

Reproduction is forbidden.

In the spirit of continuous improvement, our products may be changed.